



DT-7000

H48ND Series

Full-function Island Drive-up ATM



Self-owned Cash Processing
Technology



All-weather Solution



Ultimate Reliability



Premier Security



Flexible Scalability

The H48ND is a full-function drive-up ATM in an island style designed to cope with all weather conditions. It offers cash withdrawal, bundle cash and check deposit as well as a broad range of other services, such as funds transfer, bill payment, statement printing, envelope depositing, etc. With compact transaction area, large screen and short reach, H48ND is an ideal solution for your demand of drive-up banking, delivering great consumer usability across a wide range of vehicles.

H48ND Full-function Island Drive-up ATM

Features

All-weather Solution: Heat insulation layer and built-in heating module protect against extreme temperature, water diversion design reinforces the water-proof performance of the machine.

Ultimate Reliability: High speed and large capacity of cash processing units, unique offline diagnostic system and large volume paper roll of receipt printer minimize down-time

Premier Security: Tamper-proof card slot, anti-skimming technology, high resolution camera and DVR guarantee secure transaction environment.

Flexible Scalability: A wide range of upgrade options are available such as bill payment, prepaid card top-up, fund transfer as well as statement printing.

Specifications

Controlling Unit

- Intel® Core™ i3/i5/i7 3.3Ghz CPU, 4G RAM (up to 16GB)
- 500G HDD (Dual HDD support), DVD-RW
- Windows® XP / 7 / 10

Banknote Processing Unit

- High-speed bunch dispenser:
 - Dispensing speed: 7 notes per second
 - Max. 100 notes per transaction
 - Cassette capacity: max. 3,500 notes*
 - Max. 4 cassettes
 - Reject capacity: max. 300 notes*
 - Retract capacity: max. 300 notes*
- OCR for note serial number recognition (opt.)
- Banknote & check acceptor:
 - Processing speed: 6 notes or 1 check per second
 - Escrow capacity: 100 notes or 50 checks /mixed
 - Cassette capacity: 2,000 notes or checks per cassette*
 - 2 cassettes
 - Retract bin capacity: 100 notes
 - Reject bin capacity: 50 notes

Customer Interfaces

- Display:
 - 15" TFT color LCD with 2*4 function keys
 - Optional brightness of screen
- Keypad:
 - Tactile 4*4 alphanumeric keypad
 - PCI compliant EPP
- DIP Card reader:
 - Motorized card reader (opt.)

- Retract card capacity: max. 30 cards (opt.)
- Anti-skimming design
- EMV Level 1 and Level 2 compliant
- Contactless smart card reader (opt.)
- Receipt printer:
 - 80mm 203DPI graphical thermal printer
 - Capture and retract capability
- Journal printer (opt.):
 - High speed dot matrix journal printer
 - Thermal printer
- ADA audio
 - Compliant with ADA, high quality audio and/or headset jack
- Check processor (opt.)
- Envelope depositing (opt.)
- 1D & 2D barcode scanner (opt.)
- A4 Statement Printer (opt.)

Security

- UL291 Level 1 safe
- CEN L Safe (opt.)
- Electronic lock
- Mechanical combination lock (opt.)
- EMV Level 1 and Level 2 certified
- DVR surveillance system (opt.)
- Transaction image capture for surveillance (opt.)
- PCI compliant EPP
- Sonic alarm modules (opt.)

Maintenance

- 10.4" LCD service panel with touch screen (available on rear access model)
- Front, rear and side access

Working Environment

- Temperature:
 - 31°F (-35°C) to 122°F (50°C) (for subzero temperature, optional hearing unit is required)
- Relative humidity:
 - 20% to 95% (40°C, non-condensing)

Dimensions & Weight

- Height: 56.3in. (1430mm)
- Width: 40.9in. (1040mm)
- Depth: 37.8in. (960mm)
- Weight: 2336.9lbs (1060kg)

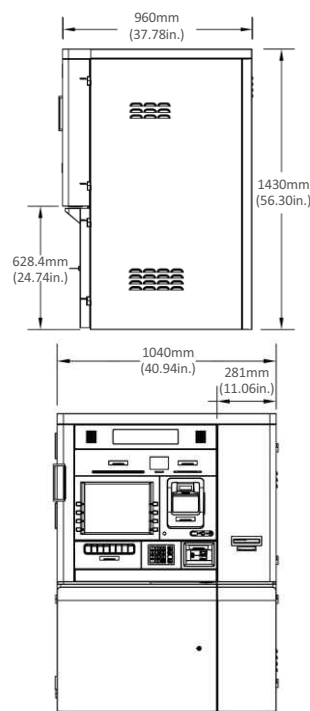

*The actual capacity is subject to the thickness and fitness of local currency.



MVP

Authorized GRGBanking Re-Seller

Jeremiah O'Conner
(415) 483-1524 | sales@mvp atm.com
[Click here](#) to schedule a meeting

Specifications are subject to update without prior notice.
Please consult GRGBanking or its representative for the latest information.